

HELICHECK PRECISION/ADVANCED/3D

Optical CNC measuring machines
for non-contact tool measurement



Key parameters

Fully automated measuring machines
HELICHECK PRECISION/ADVANCED/3D for
rotation-symmetrical tools. For tool diameters
from 2 to 320 mm, tool lengths up to 420 mm.
Tool weight up to 25 kg.



Grinding



Eroding



Laser



Measuring



Software



Customer Care

Walter Maschinenbau GmbH

WALTER has produced tool grinding machines since 1953. Today, our product range is supplemented by tool eroding machines and fully automated CNC measuring machines in the HELICHECK series for contactless complete measurement of tools and production parts.

Walter Maschinenbau GmbH is part of the UNITED GRINDING Group. Together with our sister company, Ewag AG, we consider ourselves to be a supplier of systems and solutions for the complete machining of tools and can offer a wide range of products, including grinding, rotary eroding, laser machining, measurement and software.

Our customer focus and our global sales and service network of company-owned locations and employees has been appreciated by our customers for decades.

HELICHECK PRECISION/ ADVANCED / 3D

HELICHECK PRECISION and HELICHECK ADVANCED can measure complex geometries of rotation-symmetrical tools with a reproducible accuracy of 1.5μ . Fully automated, contact-free, wear-free and precise. Both machines offer added value with the measurement of production goods like grinding wheels and diamond dressing rolls. The HELICHECK 3D generates quickly and easily 3D point clouds of tools and production goods.



Measuring



Software

The HELICHECK 3D at a glance

Application

- Fully automated measurement of complex profiles and forms of rotation-symmetrical tools and production goods
- Direct results feedback
- Ideal for in-process quality control

The Machine

- Low-vibration, solid granite basis for highest measurement precision
- 3-axis CNC machine HELICHECK PRECISION
- 4-axis CNC machine HELICHECK ADVANCED, additional CNC axis as well as two front light cameras for complete measurements, incl. rake angle, clearance angle, etc.
- Certified accuracy $E_1 = (1.8 + L/300) \mu\text{m}$
- Repeat accuracy $\leq 1.5 \mu\text{m}$
- For use in production or in the measuring room
- Numerous options



HELICHECK PRECISION – Optical 3-axis CNC measuring machine with the best price-performance ratio on the market.

Software

- WALTER “Quick Check Modular QCM” measurement software
- “Easy Check” for automatic profile detection
- “Quick Check Grinding Wheel” option for preparing the grinding wheels for the production machine
- “Teach-in Mode” option for freely programmable measuring
- Numerous other options for increasing efficiency



HELICHECK ADVANCED – Optical 4-axis CNC measuring machine with three cameras for complete tool measurement.

The HELICHECK PRECISION/ADVANCED at a glance

Application

- Generation of 3D point clouds - Measurement of outer contour and fully automatic digitizing of tools
- Various measurement and analysis options
- Outstandingly easy and meaningful

The Machine

- Low-vibration, solid granite base for the highest precision of measurement
- 4-axis CNC machine HELICHECK 3D, additional CNC axis and laser sensor for measuring the outer contour and for generating 3D point clouds
- Certified accuracy $E1 = (1.8 + L / 300) \mu\text{m}$
- Repeat accuracy $\leq 1.5 \mu\text{m}$
- For use in production or in the measuring room
- Numerous options



HELICHECK 3D – optical 4-axis CNC measuring machine with backlight camera and laser sensor for measuring the outer contour and to generate 3D point clouds

Software

- WALTER Measurement Software 3D Tool Analyzer and 3D Matcher
- “Easy Check” for automatic profile detection
- Option: “Quick Check Grinding Wheels” to prepare the grinding wheels for the production machine
- Option: “Teach-in Mode” for freely programmable measuring
- Numerous other options to increase efficiency

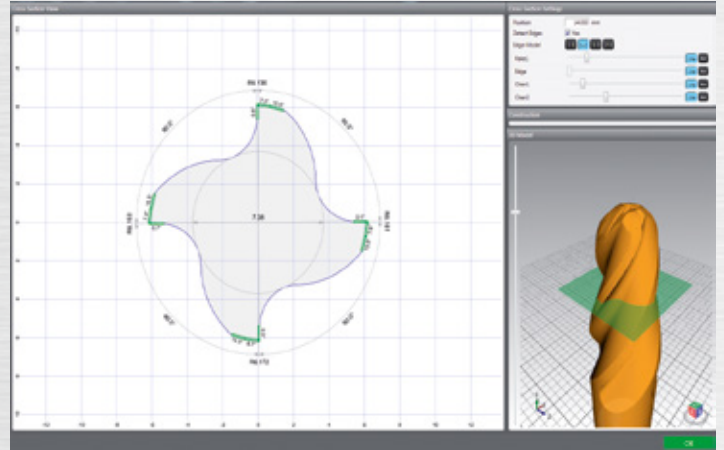

3D Tool Analyzer

A powerful software for the analysis of the 3D Model. Easily navigate to the position along the tool length and measure the most important parameters instantly. The convenient slider control let's you do any kind of slices through the tool's cross-section. Important parameters such as diameter, core diameter, indexing, rake and clearance angles but also spiral angle – even with variable lead – are all being measured fully automatically. Mark a whole section along the tool length and measure average values. It is really straight forward, without any further programming.

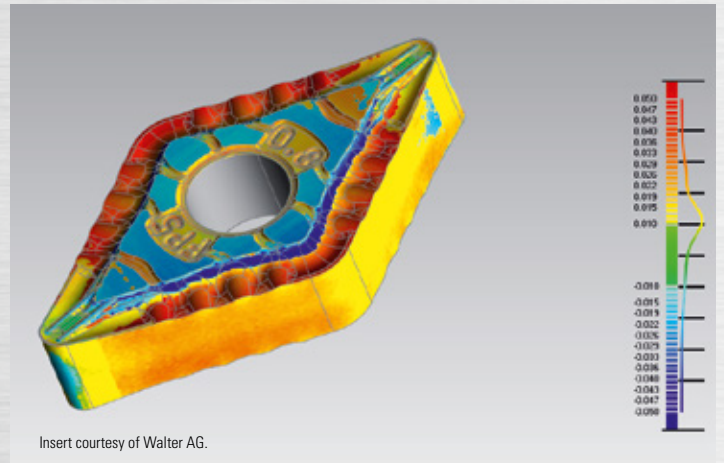

3D Matcher

Compare two models to each other. The 3D Matcher enables the operator to overlay two models and simply match them to each other. The colors represent the deviation and make it very simple to interpret the results. Scan your master part and save it as the master model. Then scan production parts and get an immediate feedback about quality and tolerance. Get immediate information about a whole batch of tools by simply comparing one tool to another. It is quick, it is convenient. It is the 3D Matcher.

Contact-free precision measurement technology



Wide range of applications

HELICHECK PRECISION, HELICHECK ADVANCED measure a broad range of tools and production goods. The HELICHECK 3D generates the corresponding 3D point clouds.

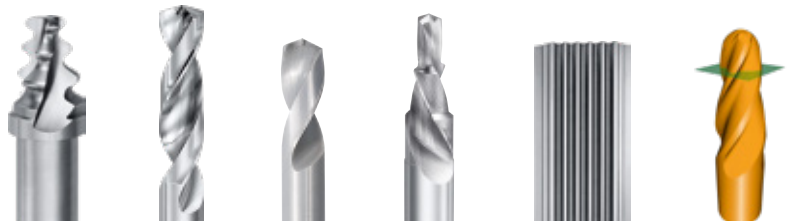



Referenz E₁: Standard for real precision

The E₁ value is the most important machine-specific characteristic when evaluating a measuring machine. It defines the one-dimensional deviation in length measurement parallel to the axis of coordinate measuring systems. The smaller the E₁ value, the smaller the area of the measurement deviation and the more precisely it describes the actual value.

For HELICHECK PRECISION, HELICHECK ADVANCED and HELICHECK K 3D, the $E_1 = (1.8 + L/300) \mu\text{m}$. Recurring measuring tasks are saved in the system and can be repeated any number of times. The repeat accuracy is $< 1.5 \mu\text{m}$.



Innovative WALTER measuring technology

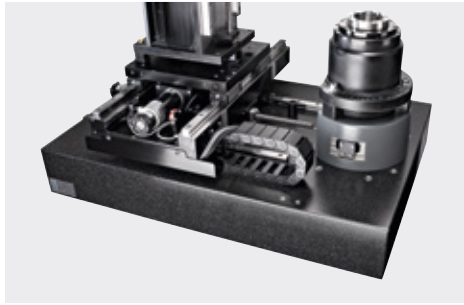

- Vibration-damping, thermostable
- Contact-free measurement
- Certified accuracy
- Wide range of applications

Solid granite base

A solid granite base, thanks to its high weight, provides the basis for accuracy and precision. It has a vibration-damping effect and is thermostable. These are the pre-conditions for the highest measuring accuracy and reliable measurement results.

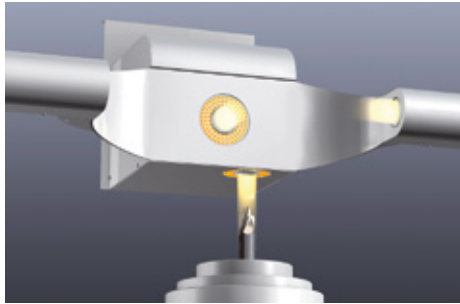

3C Direct View

HELICHECK PRECISION and HELICHECK ADVANCED have optical systems without moving parts. Its three installed cameras are fitted with LED light sources. Glass scales in the linear axes for the highest positioning accuracy. Contact-free measurement also ensures genuine wear-free performance and a high long-term stability of results.

Certified accuracy

According to VDI/VDE 2617, the accuracy of a measuring machine is evaluated by various measurements at various positions on a certified measurement standard. WALTER uses a certified step gauge or optionally a glass scale for increased accuracy. The standard calls for at least three measurements. WALTER performs ten measurements. The high accuracy of the glass scale is certified by the calibration certificate from the Physikalisch-Technischen Bundesanstalt (Germany's national metrology institute).

Options for more measuring comfort

- Ergonomic workplace
- Short setup times
- New range of flat parts

Light table

With this option, which performs the function of the coordinate measuring unit, flat parts are opened up for measurement as a spectrum of parts. Basic assembly via auto-centring and automatic detection/selection of software functions.



Modular adapter spindle

The spindle insert adapter can easily be changed in seconds without additional set-up time. The following spindle insert adapters are available:

- ISO 50/40
- HSK 100/80/63/50/40/32
- Capto C4/C5/C6/C8
- VDI 30



Further spindle insert adapters or other clamping systems, e.g. automatic hydro clamp chucks, and accessories available on request.

Tip holder (centre fixture)

With all tools and rotation-symmetrical parts requiring manufacture between tips due to their technical requirements, the high runout precision must be retained even during the measuring process. WALTER offers a high-precision tip holder for this purpose which can be configured with positive or negative tips. The tip holder is assembled using an interface with auto-centring, with low set-up and setting times.



Control panel

We optionally offer work station stands for components included in the scope of supply, such as monitor, keyboard, and printer. Choose for yourself if you prefer our ergonomic work station solution or your own existing solutions.

Measurement technology software

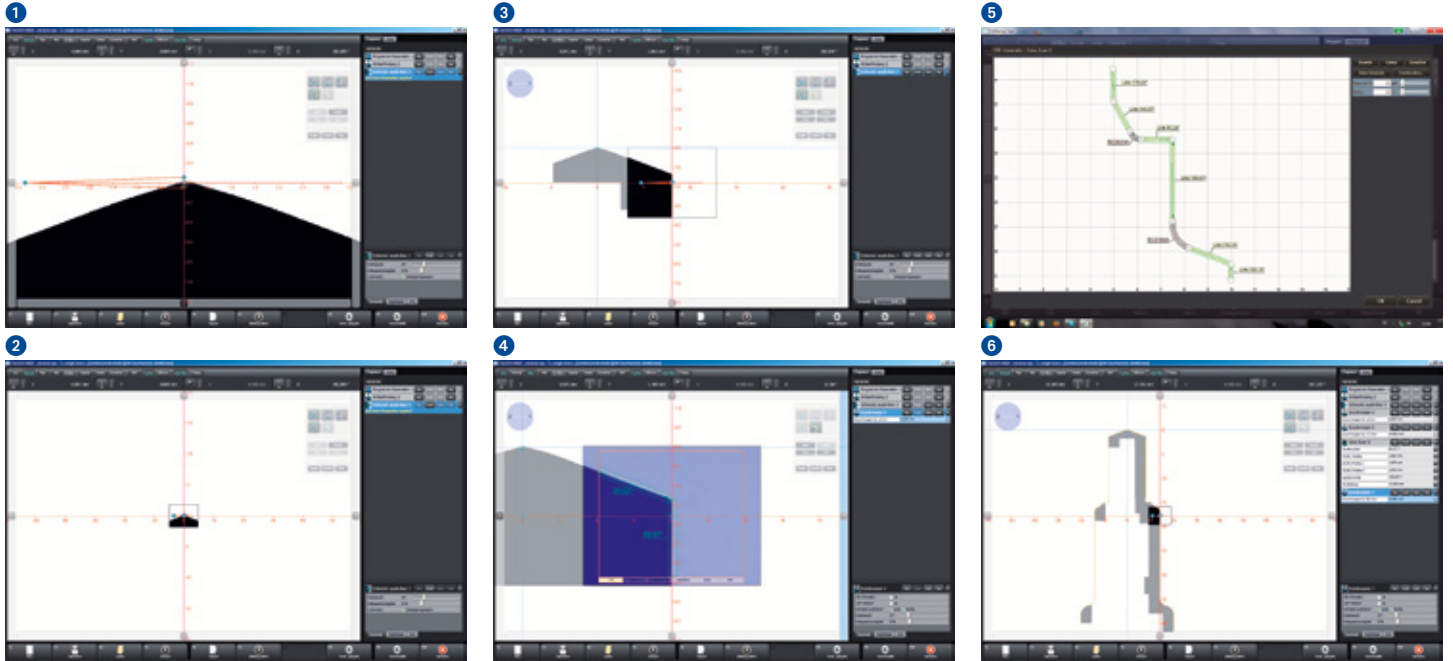

- The latest software technology
- Graphical user interface
- High measurement accuracy

WALTER, working closely with leading tool manufacturers, have developed the tool measurement technology and customised it to HELICHECK production measuring machines. For the user this means being able to rely on optimised, user-independent, reproducible results on both the HELICHECK PRECISION and the ADVANCED.

“Easy Check” software

“Easy Check” automatically manages digital tool measurement and profile detection on the HELICHECK PRECISION and HELICHECK ADVANCED via the mouse control. No complex preparatory work is required – the CNC axes of the measuring machine are controlled fully electronically during the measuring process using the intelligent mouse function. The memory function allows the transfer of measuring data which are available as measuring programs for repeat measurements. In this way, identical parts can be measured rapidly and efficiently in the fully automatic measuring sequence.

“Easy Check” benefits:

- A comfortable, high-precision alternative to hand-held measurements
- The mouse control makes manual movement to measurement positions superfluous
- Prevent scrap
- Simple operation
- No time-intensive training courses
- Flexible personnel deployment
- Save on costs thanks to quick measurements with reliable results

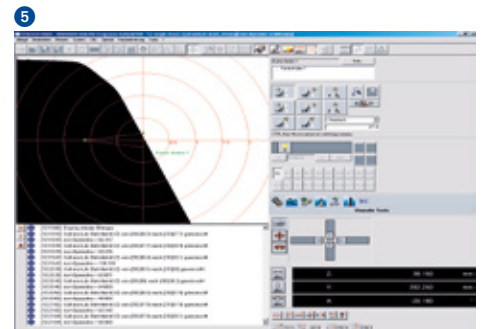
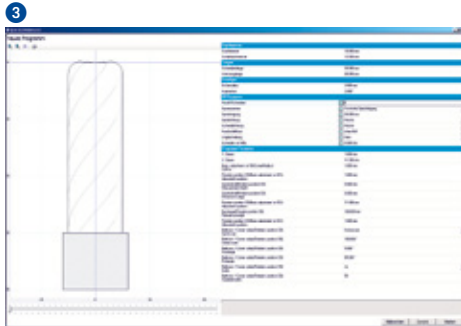
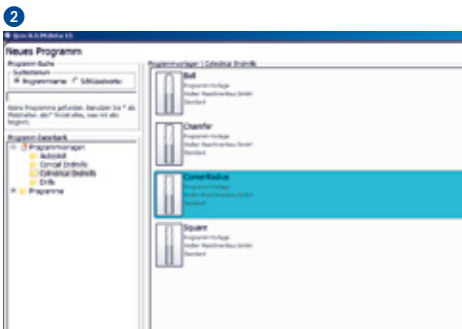
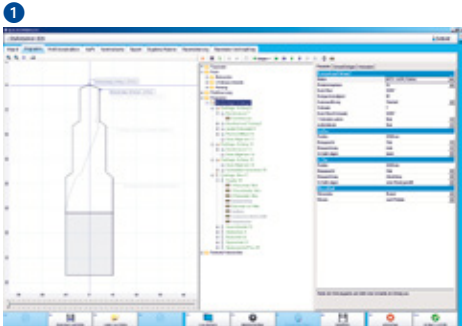

- Order management
- Highest measuring standard
- Machine-compatible

“Quick Check Modular QCM” software

Powerful measuring technology software for HELICHECK PRECISION and HELICHECK ADVANCED especially for the control of optical CNC axis of HELICHECK measuring machines. With in-process quality controls, “QCM” acts as an interface to the convenient WALTER tool software HELITRONIC TOOL STUDIO. The standard “QCM” software includes the following modules:

- “QCM Order Management” – Database-backed management of order data, measurement data and measuring programs, and
- “QCM Measurement Technology Software” – a configured software for measuring tools and creating measuring programs incl. Autocheck.

With the integrated “Order Management” and “QCM”, you can manage all measuring programs throughout your organisation and organise and clearly structure all data in a single location. A convenient search function allows you to find all programs and information by ID number or text comment rapidly.

In addition to this, the WALTER “Quick Check Grinding Wheels” software and/or “Teach-in Mode” can also be linked in order to manage these programs centrally here.

“QCM” advantages:

- Quick and easy data storage based on pre-defined templates gives you reliability.
- You work to customer requirements by adjusting the program templates to these requirements.
- Highest measuring standard through configurable geometry to inspection schedules

“Teach-in Mode” software

When linking this module with “QCM”, you can also extend your application spectrum to include any tools you desire including configuration of all kinds of inspection parts. This program contains measuring functions which can be flexibly combined with each other, with which you can create your own measuring standards.

1 QCM: Editor

2 QCM: pre-selection tool in the Wizard

3 QCM: entry of geometry parameters

4 QCM: tailor-made measuring reports for quality records

5 “Teach-in Mode” program control

WALTER measuring technology software: Quick Assistant – target reached in only three steps



Step 1
Select tool family



Step 2
Select tool type



Step 3
Select/deselect required measurement parameters and start measurement



Quick Assistant – incredibly easy to use



- Measurement in only three steps
- Simple, graphic user interface
- For cylindrical and conical milling cutters and drills
- No need to measure nominal values
- No need for records

Example icons of “Cylindrical end mills” tool family

It's never been so simple to use WALTER measuring machines. The clearly arranged icons allow the software to be used easily. No prior knowledge necessary.



Square end



Chamfer



Corner radius



Ball nose

Quality automation



- Closed quality circuit
- Reliable tolerance consistency
- High customer satisfaction

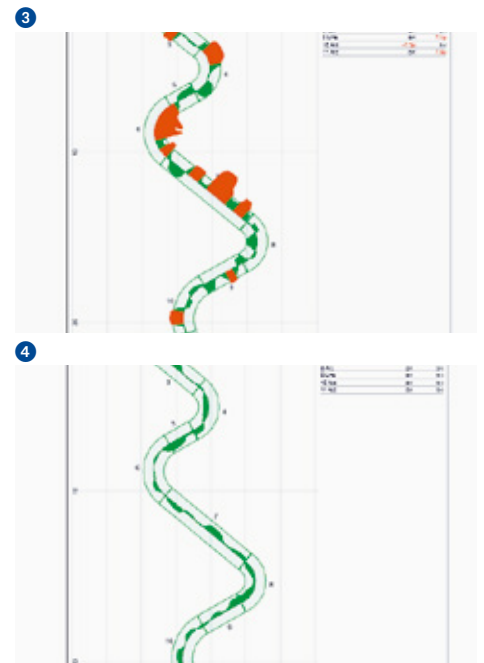
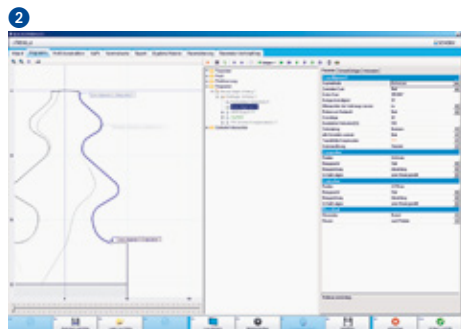

The first stage towards quality automation is the in-process quality control with automatic nominal/actual comparison and other data evaluation for e.g. statistic evaluations, direct feedback into the production process up to compliance with the documentation requirements. WALTER has prepared highly efficient software packages for this purpose.

“Form Tool Compensation FTC” software

It compares the nominal and actual contour of profiles, automatically generating a correction DXF. Not only individual points are measured, entire profiles are scanned. The deviations from the actual contour are determined with the aid of a DXF comparison and the correction DXF is sent to the WALTER tool grinding machine HELITRONIC. In this way, automatic correction determination results in a closed quality control loop – integrated in your production workflow.

Closed Loop

As we see it, this is defined as a closed quality automation with production and inspection workflows which have been adapted to each other. For example, the automatic production of pine-tree cutters with exact form precision with tool tolerances of $\pm 3 \mu\text{m}$.

“FTC” works fully automatically, user-independent and scans and measures complete profiles.

1 WALTER feedback process with HELITRONIC, HELICHECK and PC

2 FTC software for pine-tree cutters
3 Contour flow display without FTC

4 Contour flow display with FTC

Customer Care

WALTER and EWAG deliver systems and solutions worldwide for all areas of tool machining. Our claim is based on ensuring maximum availability of our machines over their entire service life. For this we have thus bundled numerous services in our customer care program.

From "Start up" through "Prevention" to "Retrofit", our customers enjoy tailor made services for their particular machine configuration. Around the world, our customers can use helplines, which can generally solve a problem using remote service. In addition to that, you will also find a competent service team in your vicinity around the world. For our customers, this means:

- Our team is close by and can quickly be with you.
- Our team will support you to improve your productivity.
- Our team works quickly, focuses on the problem and its work is transparent.
- Our team solves every problem in the field of machining tools, in an innovative and sustainable manner.



Start up

Commissioning
Extension of the guarantee



Qualification

Training
Support for production



Prevention

Maintenance
Inspection



Service

Customer service
Customer advice
Helpline
Remote service

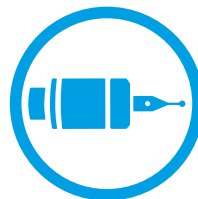

Material

Spare parts
Replacement parts
Accessories



Rebuild

Machine overhauling
Refurbishing of assemblies



Retrofit

Conversions
Retrofitting parts
Taking machines back

Technical data, dimensions

Axes

X axis (HELICHECK ADVANCED/3D only)	270 mm
Y axis	455 mm
Z axis	325 mm
A axis	360°

Accuracy

E ₁ value	$E_1 = (1.8 + L/300) \mu\text{m}$
Diameter measurement/Length measurement ¹⁾	≤ 1.5 μm
Repetition accuracy (only HELICHECK ADVANCED/PRECISION)	
Position resolution for all linear axes Y, Z	0.02 μm
Position resolution for rotation axis A (only HELICHECK ADVANCED/PRECISION)	approx. 1"
Messwertauflösung	0.25 μm

Magnification²⁾

Back light camera (only HELICHECK ADVANCED/PRECISION)	50x optional 100x
Auflichtkamera (only HELICHECK ADVANCED)	100x
Stirnkamera (only HELICHECK ADVANCED)	100x

Others

Connected load

Anschlusswert bei 230 V/50 Hz	1.5 kVA
Betriebsspannung	110 V – 240 V (50 Hz or 60 Hz)

Weight

Net weight (without options)	approx. 1,200 kg
------------------------------	------------------

Tool data

Max. diameter	320 mm
Diameter (snap gauge principle)	
HELICHECK PRECISION	220 mm
HELICHECK ADVANCED	100 mm
Max. length ³⁾	420 mm
Max. weight	25 kg

Options for HELICHECK ADVANCED / PRECISION

- Optical system: back light camera with 100x magnification
- Work stations (monitor, keyboard are included in the scope of supply of the machines)
- Change spindle
- Precision opposite tip holder
- Illuminated table for flat tools such as indexable inserts, profile tools, etc.
- Interfaces to HELITRONIC grinding machines: Wheel Data Connect, Tool Measure Interface and other interfaces upon request

Options for HELICHECK 3D

- Work stations (monitor, keyboard are included in the scope of supply of the machines)
- Change spindle
- Precision opposite tip holder
- Interfaces to HELITRONIC grinding machines: Wheel Data Connect, Tool Measure Interface and other interfaces upon request

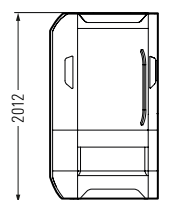
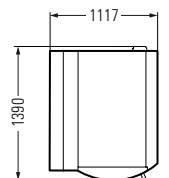

HELICHECK PRECISION / ADVANCED / 3D

¹⁾ Measured on certified stepped plug gauge with constant ambient conditions.

²⁾ The magnifications are relative to a 22" screen.

³⁾ From the theoretical taper diameter of the workpiece holder.

Measurements in mm. Subject to modifications due to technical progress and errors. We accept no responsibility for the correctness of any information given.

Creating Tool Performance

WALTER and EWAG are globally acting market-oriented technology and service companies, and are system and solution partners for all areas of tool machining. Our range of services is the basis for innovative machining

solutions for practically all tool types and materials typical for the market with a high degree of added value in terms of quality, precision, durability and productivity.



Grinding – Grinding of rotationally symmetrical tools and workpieces

WALTER machines	Use	Materials	Tool dimensions ¹⁾ max. length ²⁾ / diameter
HELITRONIC ESSENTIAL	P R	HSS TC C/C CBN	255 mm / Ø1 – 100 mm
HELITRONIC MINI POWER	P R	HSS TC C/C CBN	255 mm / Ø1 – 100 mm
HELITRONIC MINI AUTOMATION	P R	HSS TC C/C CBN	255 mm / Ø1 – 100 mm
HELITRONIC BASIC	P R	HSS TC C/C CBN	350 mm / Ø3 – 290 (320) mm
HELITRONIC POWER	P R	HSS TC C/C CBN	350 mm / Ø3 – 290 (320) mm
HELITRONIC POWER 400	P R	HSS TC C/C CBN	520 mm / Ø3 – 315 mm
HELITRONIC VISION 400	P R	HSS TC C/C CBN	370 mm / Ø3 – 315 mm
HELITRONIC VISION 400 L	P R	HSS TC C/C CBN	420 mm / Ø3 – 315 mm
HELITRONIC VISION 700 L	P R	HSS TC C/C CBN	700 mm / Ø3 – 200 mm
HELITRONIC MICRO	P R	HSS TC C/C CBN HSS TC C/C CBN	120 mm / Ø0.1 – 12.7 mm 120 mm / Ø3 – 12.7 mm

EWAG machines	Use	Materials	Tool dimensions ¹⁾ max. length ²⁾ / diameter
EWAMATIC LINEAR	P R	HSS TC C/C CBN PCD	200 mm / Ø0.2 – 200 mm
PROFILE LINE	P R	HSS TC C/C CBN	255 mm / Ø1 – 100 mm
WS 11/WS 11-SP	P R M	HSS TC	– / up to Ø25 mm
RS 15	P R M	HSS TC C/C CBN PCD	– / up to Ø25 mm



Eroding – Electrical discharge machining and grinding of rotationally symmetrical tools

WALTER machines	Use	Materials	Tool dimensions ¹⁾ max. length ²⁾ / diameter
HELITRONIC DIAMOND EVOLUTION	P R	HSS TC C/C CBN PCD	185/255 mm / Ø1 – 165 mm
HELITRONIC POWER DIAMOND	P R	HSS TC C/C CBN PCD	350 mm / Ø3 – 290 (400) mm
HELITRONIC POWER DIAMOND 400	P R	HSS TC C/C CBN PCD	520 mm / Ø3 – 380 mm
HELITRONIC VISION DIAMOND 400	P R	HSS TC C/C CBN PCD	370 mm / Ø3 – 315 mm
HELITRONIC VISION DIAMOND 400 L	P R	HSS TC C/C CBN PCD	420 mm / Ø3 – 315 mm



Software – The intelligence of tool machining and measuring for production and regrinding



Customer Care – Comprehensive range of services

Use: P Production R Regrinding M Measuring

Materials: HSS High speed steel TC Tungsten carbide C/C Cermet/ceramics CBN Cubic boron nitride PCD Polycrystalline diamond CVD-D Chemical vapour deposition MCD/ND Monocrystalline diamond/natural diamond



Grinding – Grinding of indexable inserts

EWAG machines	Use	Materials	Indexable inserts ¹⁾ Inscribed / circumscribed circle
EWAMATIC LINEAR	P R	HSS TC C/C CBN PCD	Ø3 mm / Ø50 mm
PROFILE LINE	P R	HSS TC C/C CBN	Ø3 mm / Ø50 mm
COMPACT LINE	P R	HSS TC C/C CBN PCD	Ø3 mm / Ø50 mm
INSERT LINE	P R	HSS TC C/C CBN	Ø3 mm / Ø75 mm
RS 15	P R M	HSS TC C/C CBN PCD	– / up to Ø25 mm



Laser – Laser machining of indexable inserts and/or rotationally symmetrical tools

EWAG machines	Use	Materials	Tool dimensions ¹⁾ max. length / diameter
LASER LINE ULTRA	P R	TC C/C CBN PCD CVD-D MCD/ND	250 mm / Ø0.1 – 200 mm
LASER LINE PRECISION	P R	CBN PCD CVD-D MCD/ND	250 mm / Ø0.1 – 200 mm

EWAG machines	Use	Materials	Indexable inserts ¹⁾ Inscribed / circumscribed circle
LASER LINE ULTRA	P R	TC C/C CBN PCD CVD-D MCD/ND	Ø3 mm / Ø50 mm
LASER LINE PRECISION	P R	CBN PCD CVD-D MCD/ND	Ø3 mm / Ø50 mm



Measuring – Contactless measurement of tools, workpieces and grinding wheels

WALTER machines	Use	Tool dimensions ¹⁾ max. length / diameter
HELICHECK PRECISION	M	420 mm / Ø1 – 320 mm
HELICHECK ADVANCED	M	420 mm / Ø1 – 320 mm
HELICHECK PRO	M	300 mm / Ø1 – 200 mm
HELICHECK PRO LONG	M	730 mm / Ø1 – 200 mm
HELICHECK PLUS	M	300 mm / Ø0.1 – 200 mm
HELICHECK PLUS LONG	M	730 mm / Ø0.1 – 200 mm
HELICHECK 3D	M	420 mm / Ø3 – 80 mm
HELISET PLUS	M	400 mm / Ø1 – 350 mm
HELISET	M	400 mm / Ø1 – 350 mm

¹⁾ Maximum tool dimensions are dependent on the tool type and geometry, as well as the type of machining.

²⁾ From the theoretical taper diameter of the workpiece holder.



Walter Maschinenbau GmbH
Jopestr. 5 · 72072 Tübingen, Germany
Tel. +49 7071 9393-0
Fax +49 7071 9393-695
info@walter-machines.com

For worldwide contact details, please visit
www.walter-machines.com

