

PROFIMAT XT

The new benchmark for
productivity and precision

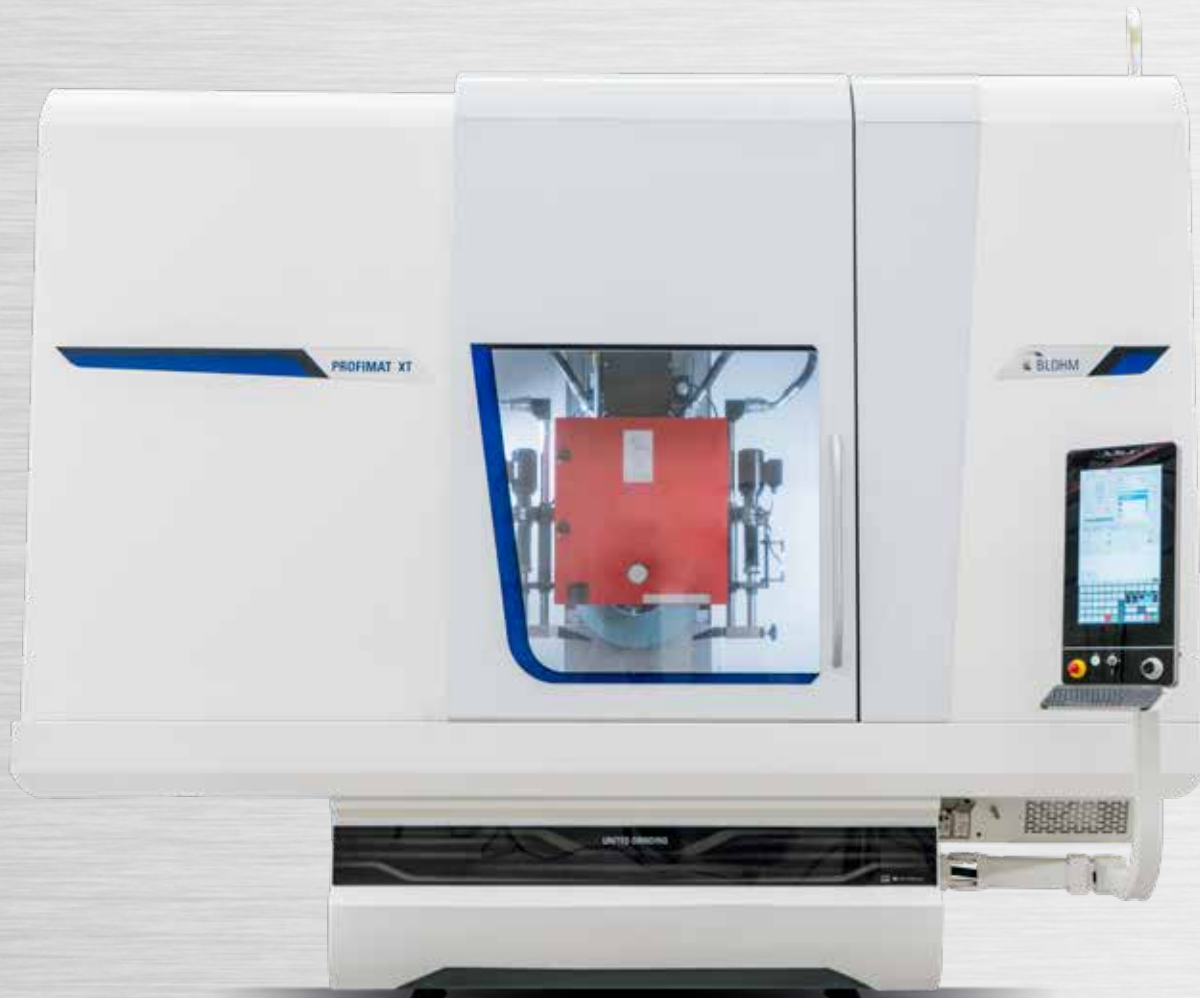

Key data

The PROFIMAT XT - high-quality grinding
technology for profile grinding.

- Five machine sizes (408/412/608/612/620)
- Grinding spindle drive up to 62 kW
- Four integrated technologies

Blohm Jung GmbH

Productivity, performance and precision – three attributes which users worldwide associate with surface and profile grinding machines from BLOHM and JUNG. Our machines have been in use worldwide for decades in widely varying fields of application and under very different conditions. The experience gained from over 35,000 delivered machines is constantly incorporated into further developments and innovations, increasing our customers' production efficiency even further. The product portfolio of Blohm Jung GmbH extends from surface grinding machines through application-oriented universal machines to customer-oriented production machines. Our service and technology specialists support our customers throughout the entire lifecycle of the machine. From grinding tests through training and maintenance contracts to retrofits, we offer our customers prompt and personal advice.

In 2008 the two established brands BLOHM and JUNG merged under one roof. Blohm Jung GmbH has thus combined its extensive know-how and constantly enables new, higher standards in the area of precision, quality and cost efficiency. There are also many opportunities for tailoring production solutions to individual customer requirements.

As part of the UNITED GRINDING Group, Blohm Jung GmbH is represented internationally with offices in India, China, Russia and the USA. A further 40 sales and service agencies guarantee a worldwide presence and customer proximity. The company's main locations are the development and production facility in Hamburg and the service and technology center in Göppingen.

PROFIMAT XT

Higher axis speeds, higher accelerations and increased system rigidity – the combination of these improved influencing factors consistently leads to an increase in productivity while at the same time improving workpiece quality. These characteristics distinguish the PROFIMAT XT as a robust and powerful production grinding machine.

Characteristics

Dimensions

- 5 machine sizes with the following grinding ranges:
 - 400×800 mm
 - 400×1.200 mm
 - 600×800 mm
 - 600×1.200 mm
 - 600×2.000 mm

Hardware

- Modular system
- High quality components comprising spheroidal graphite iron
- Thermal and vibration engineering characteristics optimized via finite element analysis
- Precision linear guideways
- High quality, recirculating ballscrews



Software

- Siemens 840D solution line with safety functions
- Optimal operator guidance
- Programming with menu-guided grinding and dressing cycles

The PROFIMAT XT has been designed purely as a high performance profile grinding machine for flexible applied technology. The PROFIMAT XT is the right choice for applications where the production process requires high metal removal rates.

Grinding spindle drives up to 62 kW guarantee outstanding performance using conventional, CD or IPD as well as all CBN grinding methods.

Pre-loaded anti-friction guideways in all machine axes guarantee the necessary system rigidity and reduce maintenance requirements. The extremely efficient BLOHM software ensures exact interpolation of the axes and thus high workpiece quality. A large spectrum of standard accessories and special part clamping and part handling systems offer a quick and economic adaptation to customer specific production requirements at high quality.



CNC Control

The comfortable solution for profile grinding applications



The best machines in a performance class offer more than just technically advanced components. Their high capabilities are made possible by the use of perfectly matched software and technology.

The CNC control Siemens Sinumerik 840D solution line with graphical operator guidance especially developed for grinding applications guarantees an optimal process. The simple programming is supported by menu guided grinding and dressing cycles.

The software option GripsProfile is a comfortable tool, especially for the single piece and batch production, for the automatic generation of grinding and dressing programs.



Thread rolling die



5-axes continuous path control grinding



Contour parallel dressing



CD-grinding



Configurable HMI

Digital Solutions™



Digital Solutions™ makes sure you have everything under control – at all times. The package offers monitoring of machine parameters and processes and provides instant connectivity and communication.

Optimum dressing



Table mounted dresser type PA-TL 200S for diamond rolls up to a width of 200 mm or for contour dressing with universal diamond dressing disks and a rough dressing disk.



Overhead dressing system PEA-K for IPD and CD grinding methods designed for a grinding wheel width of up to 200 mm.

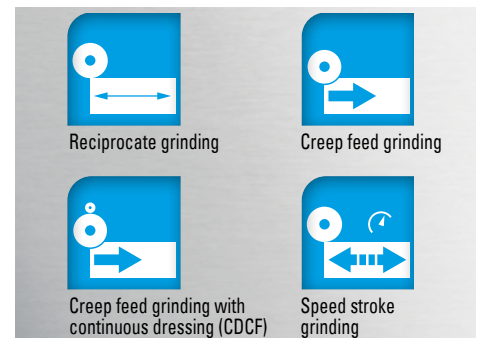

FIT – Four Integrated Technologies: The BLOHM PROFIMAT XT combines four technologies in one machine.

BLOHM Solutions

Automotive industry and suppliers



Connecting rod and cap

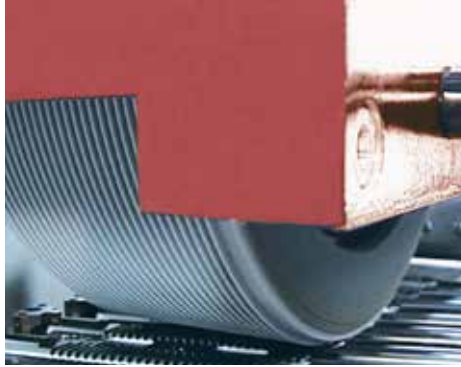

Steering racks

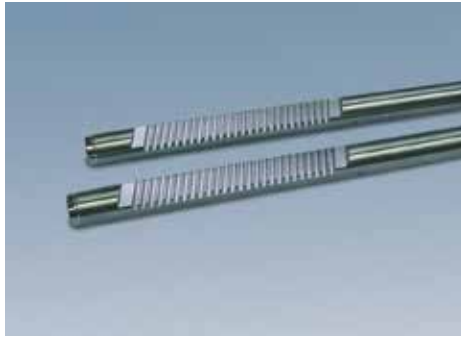

Turbine industry

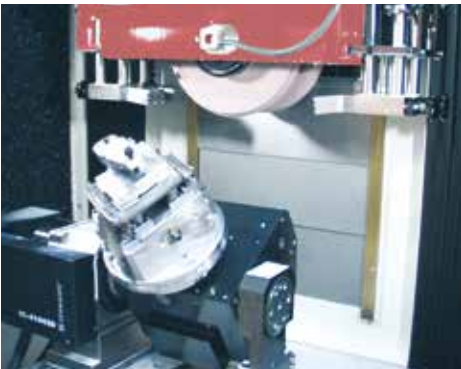

Turbine vane – 5 axes cont. path controlled grinding

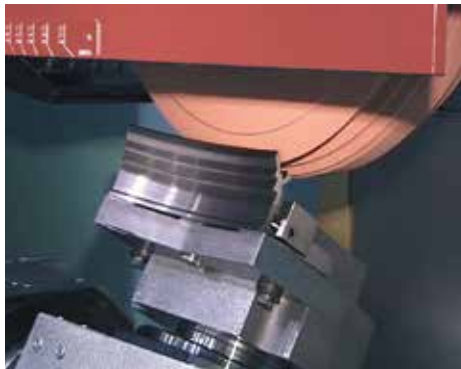

Shroud segment – multiple operations in 1 set-up

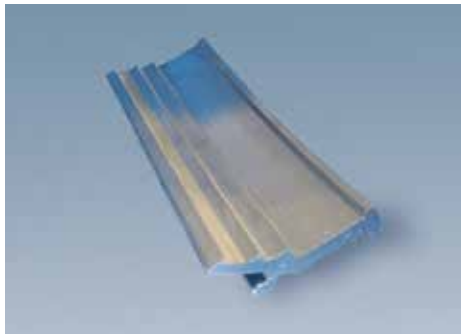
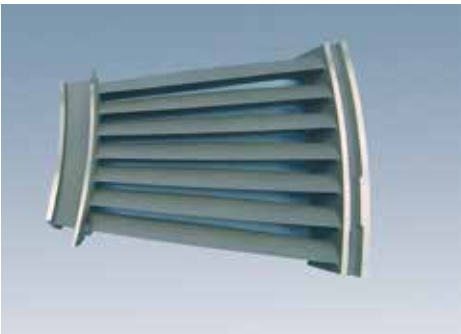

Tool and die industry



Thread rolling die



Rail

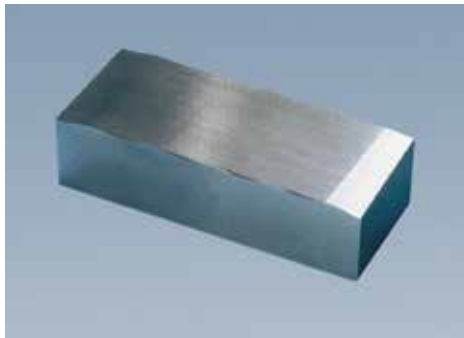

Machine building



Tooth rack

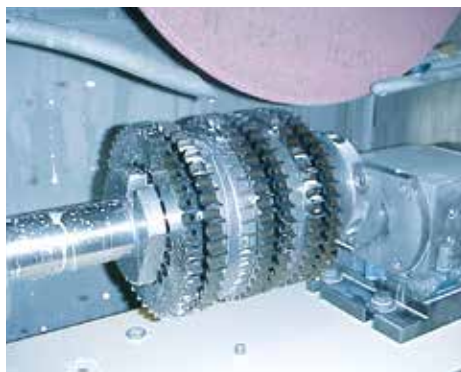

Transfer drum



Guideway

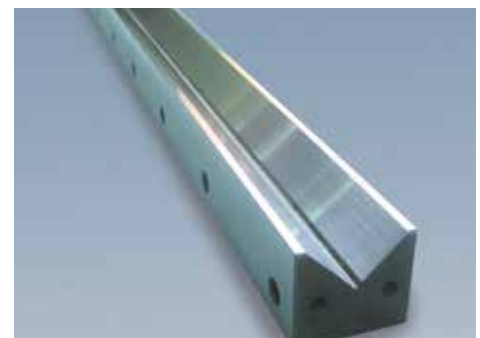
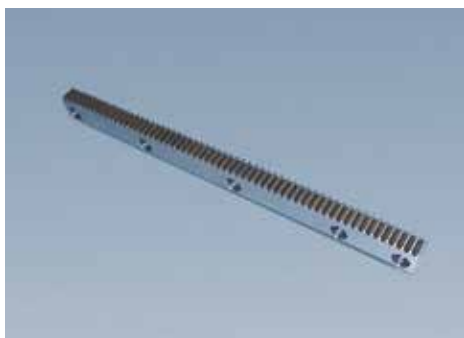

Customer Care



BLOHM and JUNG surface and profile grinding machines should fulfill the customer's requirements for as long as possible, work cost-effectively, function reliably and be available at all times. From "start up" through to "retrofit" – our Customer Care is there for you throughout the working life of your machine. 6 professional helplines and more than 25 service technicians are available in your area, wherever you are in the world.

- We will provide you with fast, uncomplicated support.
- We will help to increase your productivity.
- We work professionally, reliably and transparently.
- We will provide a professional solution to your problems.



Start up
Commissioning
Warranty extension



Qualification
Training
Production support



Prevention
Maintenance
Inspection



Service
Customer service
Customer consultation
HelpLine
Remote service



Digital Solutions™
Remote Service
Service Monitor
Production Monitor

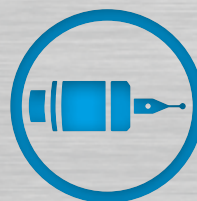

Material
Spare parts
Replacement parts
Accessories



Rebuild
Machine overhaul
Assembly overhaul



Retrofit
Modifications
Retrofits
Machine trade-in

Technical data

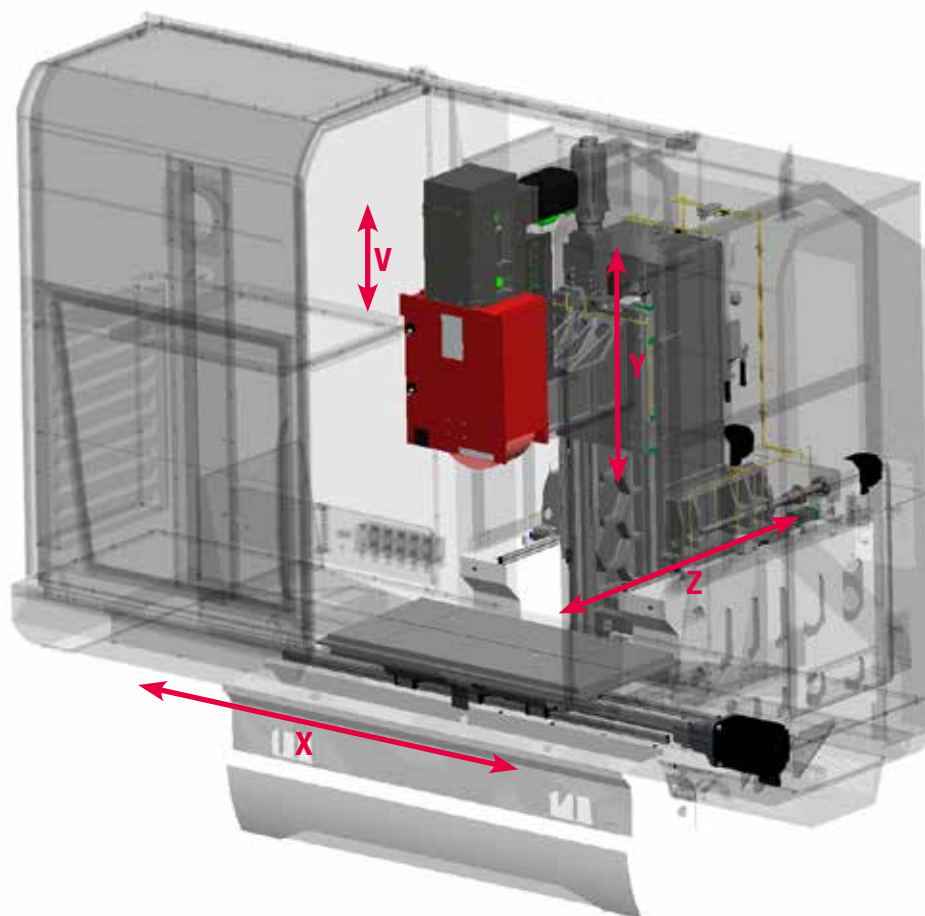

PROFIMAT XT		408	412	608	612	620
Grinding Range	mm	400 × 800	400 × 1.200	600 × 800	600 × 1.200	600 × 2.000
Table clamping area with auxiliary surface	mm	400 × 1.300	400 × 1.700	600 × 1.300	600 × 1.700	600 × 2.500
Distance table to spindle center	mm	970				
X-axis, machine table longitudinal travel, max.	mm	1.100	1.500	1.100	1.500	2.300
Feed rate	mm/min	30 ... 40.000				
Y-axis, wheel head vertical travel	mm	800				
Feed rate	mm/min	4 ... 10.000				
Z-axis, column cross travel	mm	360	360	560	560	560
Feed rate	mm/min	4 ... 10.000				
V-axis, stroke of overhead dresser (opt.)	mm	160				
Grinding spindle drive, variable speed, AC motor	kW/rpm	44/8.000 (Option 62/8.000)				
Grinding wheel size (d x w x bore)	mm	400 × 160 × 127 (Option 500 × 200 × 203,2)				
Dimensions Width	mm	4.000	5.000	4.000	5.000	6.500
Depth	mm	2.979	2.979	3.179	3.179	3.179
Height	mm	3.485	3.485	3.485	3.485	3.485
Machine weight, without electrical cabinets	kg	7.200	7.800	8.000	8.700	10.000

We reserve the right to make technical changes



Blohm Jung GmbH

Location Hamburg

Kurt-A.-Körper-Chaussee 63-71
D-21033 Hamburg
Phone +49 40 33461 2000
Fax +49 40 33461 2001
sales-hh@blohmjung.com

Location Göppingen

Jahnstraße 80-82
D-73037 Göppingen
Phone +49 7161 612 0
Fax +49 7161 612 170
sales-gp@blohmjung.com

www.blohmjung.com

