



#### ⊕ Disk loader

Auto-load up to 90 unique tools—Any diameter—Any type- In any sequence. You can even load collets and tools separately to minimize the number of collets you need on hand. And the disk loader requires very little extra floor space.

#### Tool data

Maximum capacity	
Diam. 1/8-1/4" (3-32 mm)	40 tools
Diam. 3/4" (20 mm)	56 tools
Diam. 1/2" (12 mm)	90 tools
Maximum tool length	6 1/2" 165 mm

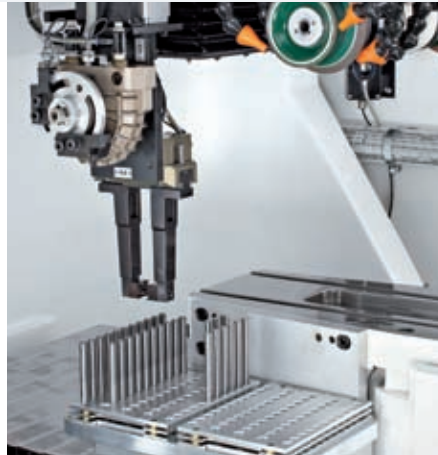

#### ⊕ ECO Loader

A simple loader that can pay for the machine by making "break time" productive. Takes NO additional floor space because the pallet is mounted directly on the workhead. Auto-load up to 20 tools of varying diameters with the standard configuration, or opt for the PLUS system and grind up to 165 in one setup.

#### Tool data

Max. capacity	
Diam. 1/8-1" (3-25 mm)	20 tools
Diam. 3/8-3/4" (10-20 mm)	49 tools
Diam. 1/4 - 5/8" (6-16 mm)	81 tools
Diam. 1/8 - 1/2" (3-8 mm)	165 tools
Max. diameter	1 1/4" 32 mm
Maximum tool diameter	6 1/2" 165 mm

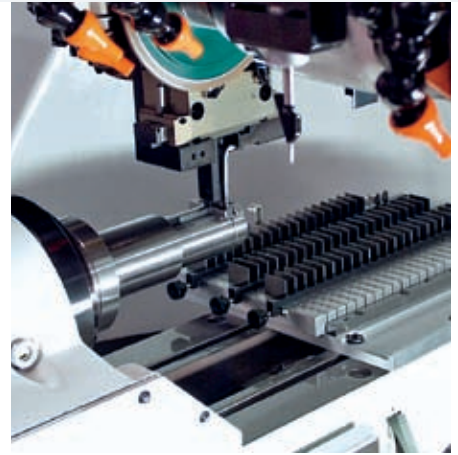

#### ⊕ Insert blade loader

A flexible loading system to automate the grinding of up to 76 woodworking insert blades. Can be added to an ECO or Disc Loader and you can switch easily between inserts and round tools. The pallet mounts on the worktable and you simply replace the standard clamping unit with a special device for inserts.

#### Tool data

Maximum insert capacity	76 pieces
(at a maximum insert width of 40 mm)	

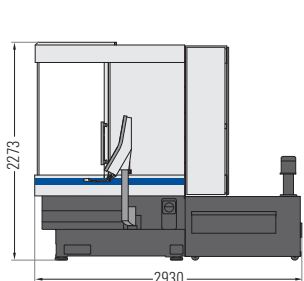

Helitronic Power

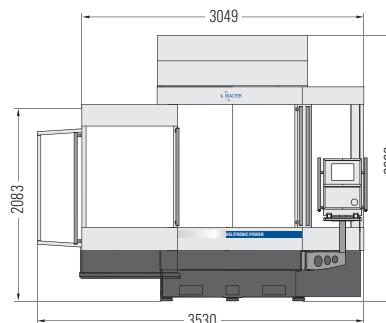
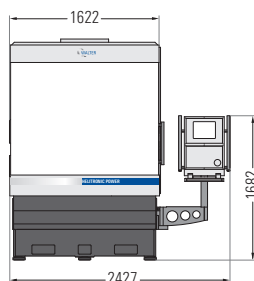

Helitronic Power with Pallet loader and grinding wheel changer

