



# INFO

Sept 2010  
Helitronic automation

## New automation for world's most popular tool grinders

**T**he Helitronic Power and Vision machines have exciting new automation options that increase your flexibility and profitability:

### Auto-loading

A new robot loader offers 40% faster changes plus the ability to handle longer and more complex parts. For example, the robot can auto-load tools up to 11.8 inches (300 mm) in length. And with the ability to add a second “floor” of pallets (for a total of 8), the loader can handle up to 3,500 tools. (The robot uses up to 7 pallets for blanks and loads completed tools into the vacated pallets). Capacities are as follows:

Diameter Range	# Tools per pallet
1.00 to 3 mm	500
3.10 to 6 mm	300
6.10 to 8 mm	120
8.10 to 12 mm	99
12.1 to 16 mm	63
16.1 to 20 mm	42

Diameter Range	# Tools per pallet
20.1 to 25 mm	30
25.1 to 32 mm	20

The loader cabinet bolts onto the side of the grinder and does not require a gantry into the machine. So it can be added to any Helitronic machine with the Fanuc control except the Mini Power.

### Traveling worktable

A new traveling worktable supports a variety of manual and automatic steadyrests and tailstocks. That includes the Arobotech steadyrest, which can support even long backtaper tools throughout the grind.

Over for more 



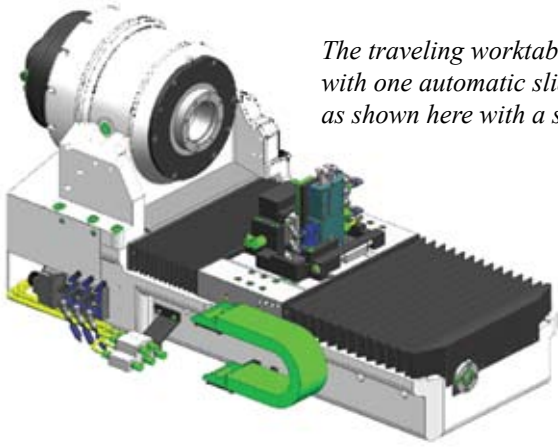

The traveling worktable is available with one automatic sliding carriage, as shown here with a steadyrest...

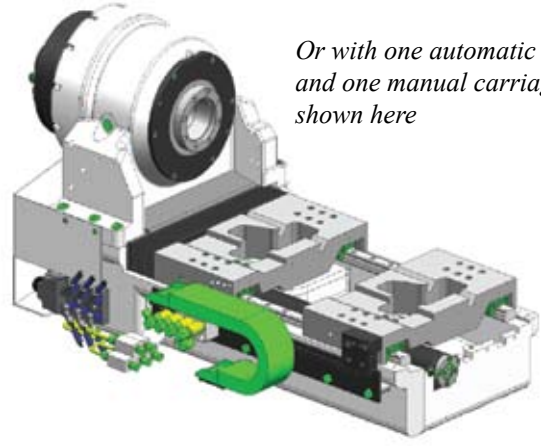

Or with one automatic carriage and one manual carriage, as shown here

## Don't forget our other recent automation advances...

A wheel changer eases setup and switches from HSS to carbide tools in seconds. And an automatic dresser maintains wheel form during long production runs. Plus Form Tool Compensation (FTC) makes it possible

to set up tight tolerance form tools in minutes, accurate to within microns. And now you can do that without a Helicheck machine, using a camera you mount in the machine. We call it FTC On Board:



### As easy as 1-2-3:

Grind a tool & measure internally with FTC On Board



Automatically create complete compensation file for the grinder



Grind a near-perfect tool & send it to your customer

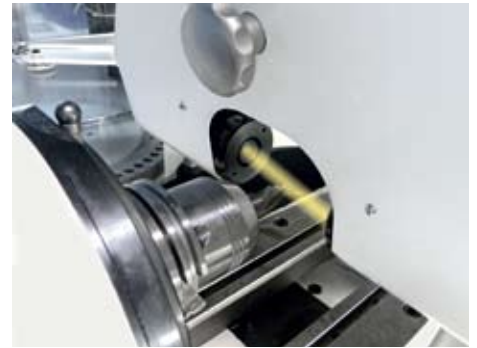

FTC On board includes a high speed gigabit camera, high power collimated LED backlighting, sealed housings for the camera and lights, & air nozzles for automatic tool cleaning

**WALTER**

KÖRBER  
SCHLEIFRING

**United Grinding Technologies  
Tool Division**

Fredericksburg, VA  
PH: 540-898-3700 • FAX: 540-898-6819  
www.grinding.com

**Give us a call!  
(540) 898-3700, Ext 2**

**Click for more info**

Most versatile tool grinders  
Best software  
Best support...worldwide



www.grinding.com