

S33

The reasonably priced
for individual requirements.

The Art of Grinding.

 **STUDER**
KÖRBER
SCHLEIFRING

Advantages

S33 – Dimensions

- Distance between centres 650/1000 mm (25.6" / 39.4")
- Centre height 175 mm (6.9")
- Max. workpiece weight 80/120 kg (176/264 lbs)

Hardware

- Optional wheelhead:
 - Turret wheelhead with two motor spindles (right/right) and an internal grinding attachment with manual swivel 2.5° Hirth or automatic swivel 1° Hirth.
 - External wheelhead with grinding wheel on the right, can be swivelled on 0 deg and 30 deg end stops.
- External and internal grinding possible in one setup
- C axis for the workhead enabling form and thread grinding
- Granitan® mineral-casting S103 machine base

Software

- Easy programming with StuderWIN on Fanuc 0i-TD with integrated PC
- StuderGRIND programming software for producing grinding and dressing programs on a PC
- Reduced setup and resetting times with Studer Quick-Set
- Standardized interfaces for peripheral devices

S33



Universally unique

Even more complex workpiece geometries can be ground in a single clamping! This is made possible by a new wheel head with two motor spindles for external grinding and an internal grinding unit. Three grinding wheels ensure that the workpiece can be machined even more individually and quickly – complete machining in a class of its own!

Customer value

- Utilize the max. grinding length with both wheels
- Motor spindle incl. frequency convertor
- Constant cutting speed is included in the standard package
- Two grinding wheels Ø 500mm
- High-frequency internal grinding spindle

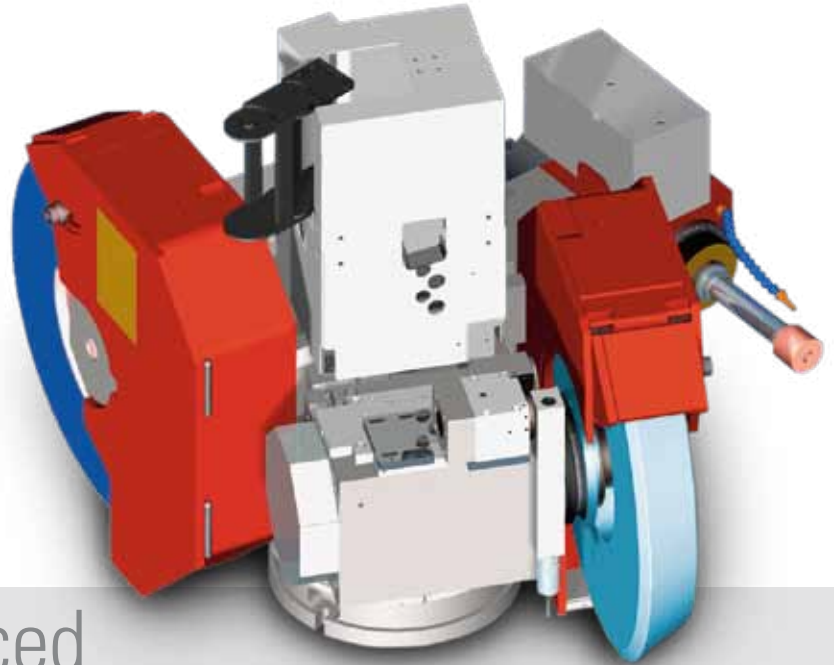

The reasonably priced
for individual requirements.

The CNC universal grinding machine for small budgets and high demands.

The S33 CNC universal cylindrical grinding machine – designed for grinding medium-sized workpieces in individual and series production – is manufactured with distances between centers of 650 mm (25.6") and 1000 mm (39.4").

The solid Granitan® S103 machine base forms the basis for a cylindrical grinding machine that is equipped with high quality components, thus guaranteeing maximum precision, performance and reliability over many years. The choice of partial or complete enclosure provides an optimum insight into the grinding process.

The practical Studer grinding software with its proven pictogramming allows even less experienced users to quickly optimize the potential of this machine. The StuderGRIND software is also available; this enables efficient program-

ming of special applications, such as form and thread grinding. The systematic development, production, assembly and testing of Studer products are carried out in a process-oriented manner and in strict compliance with the VDA 6.4 and ISO 9001 directives.

Changeover in two minutes

Changing over from grinding between centers to live spindle grinding is particularly easy on the S33. Only a few movements are needed to withdraw the tailstock to its «park position» and free up the space required for internal grinding. Reference points from grinding wheels to dressing tool and workpiece can be registered very quickly with the help of Quick-Set, the software-controlled set-up device from Studer. The new grinding cycle can then be started.

1



Granitan® mineral-casting S103 machine base

The material structure developed by Studer and which has proved its superb efficiency over many years is produced in the company's own plant using the most modern industrial techniques.

- The excellent dampening proprieties of the machine base ensures outstanding surface-quality of the ground workpieces. The service life of the grinding wheel is also increased, leading to reduced downtimes.
- Temporary temperature fluctuations are extensively compensated for by the favorable thermal behavior of Granitan®, resulting in high dimensional accuracy at all times.
- The V and flat guideways for the longitudinal and cross slides are moulded directly into the machine base and are provided with a non-abrasive Granitan® S200 slideway coating. The patented knobbed structure of the guideways largely eliminates the slip-stick effect or floating of the slides observed on conventional guideways. The guideways offer the highest possible accuracy through the entire speed range with high load capacity and dampening levels. Thanks to the robust and maintenance-free design, these excellent guideway characteristics are more or less completely retained.

- Vibration-dampng
- Thermal stability
- Non-wearing

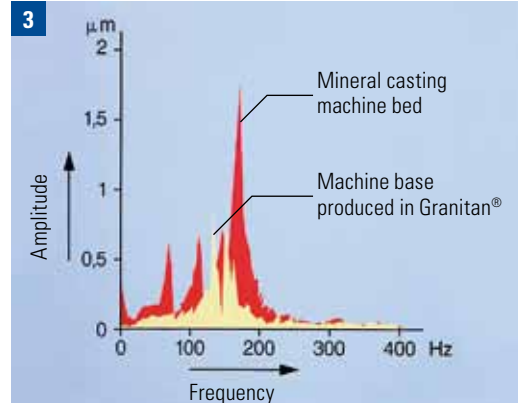

Longitudinal and cross slides

- 1 | Machine bed with longitudinal and cross guideways
- 2 | Guideways with patented surface structure
- 3 | Vibration behavior of gray cast iron and Granitan® S103
- 4 | Swivelling table with setup scale
- 5 | Machine base with longitudinal and cross slides

The longitudinal and cross slides are manufactured from high-quality gray cast iron and have highly precise, ground V and flat guideways, with the distance between the guideways optimally suited to the machine's overall rigidity. The slides rest completely on the guideways of the machine bed through the entire speed range. This provides the cornerstone for the excellent inherent grinding straightness of 0.0025 mm (0.000,010") over 650 mm (25.6") measured length. The slides are advanced by 40 mm (1.57") diameter circulating ball screws connected to a three-phase servomotor via torsion-resistant, bellow-type couplings.

These axes achieve high process speeds, on the one hand, while on the other hand the short auxiliary times also guarantee maximum precision with in-feed movements of 0.0001 mm (0.000,040"). These axes can be equipped with rotative or linear measuring systems, depending on requirements.

The top of the longitudinal slide has a surface that is ground over its entire length and acts as a support for the workhead, the tailstock, as well as accessories and devices. The scale, recessed in the table, makes it easy to set up and reset the machine.

- High-accuracy axis movements
- Auxiliary scale for setup and resetting
- Effective covering of the guideways





- Complete machining
- High output
- High cutting speed of 50 m/s (9842 sfpm)



Wheelheads

Two variants are available:

- The new **turret wheelhead** with two motor spindles and an internal grinding attachment enables grinding of even more complex work-piece geometries in a single clamping.
- An **external wheelhead** with belt-driven spindle is available for production applications. It can be manually adjusted to 0° or 30°.

The new turret wheelhead can be equipped exactly to customer requirements. Thanks to the sophisticated geometry, the entire distance between centers can be traversed with all grinding wheels. The motor spindles make a large contribution to the legendary Studer precision. They are manufactured entirely in-house.

The S33 offers maximum grinding lengths for both distances between centers.

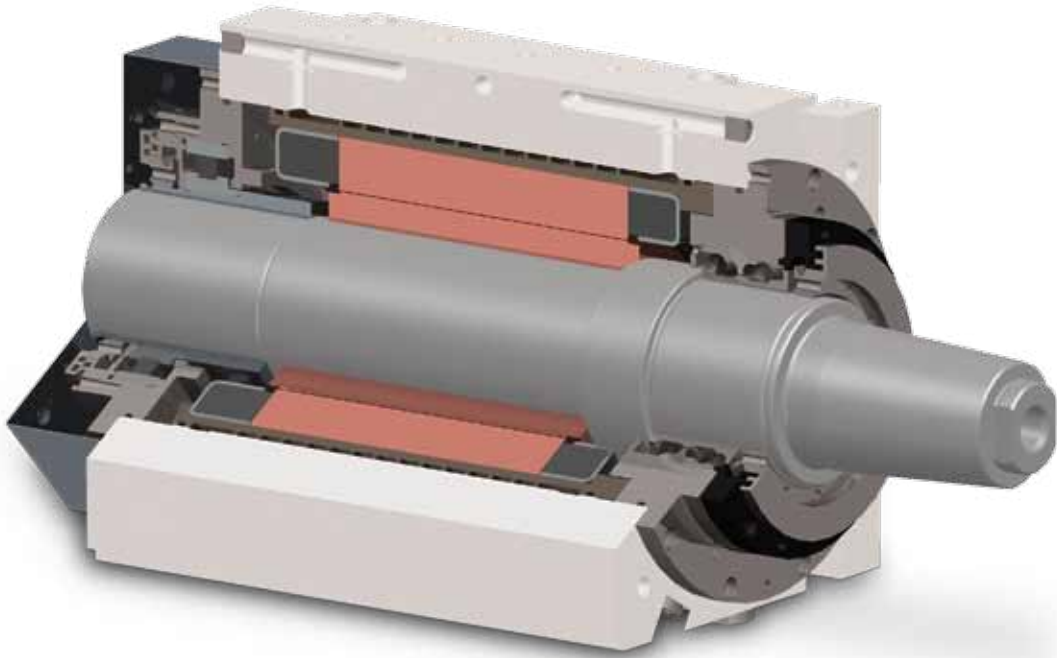

4

External

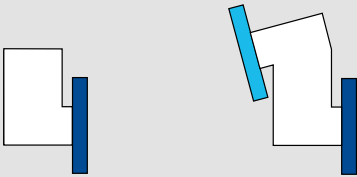

Internal

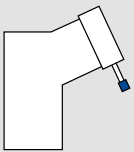

Universal

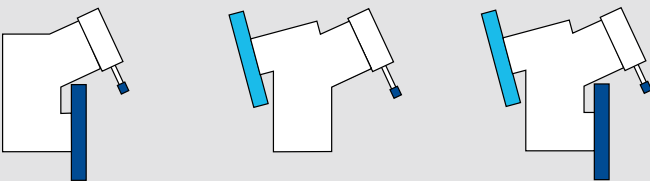

- 1 | Universal wheelhead
- 2 | Internal grinding spindle
- 3 | External wheelhead
- 4 | Motor spindle

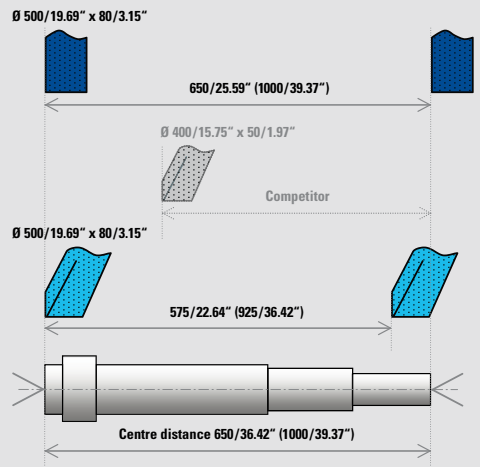

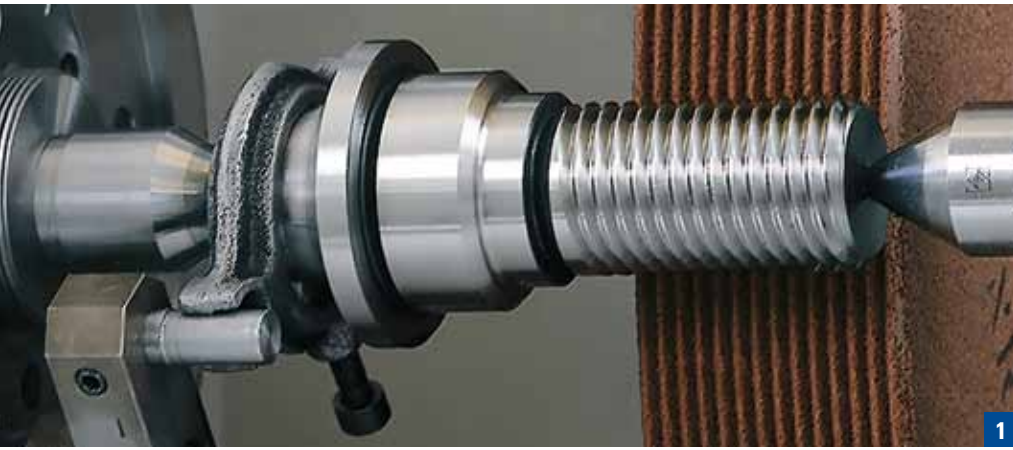

Workhead

The versatile universal workhead enables both live spindle grinding and grinding between centers. The machine can also be fitted with a specially designed chuck workhead for chuck applications. The workheads are equipped with roller bearings, are low-maintenance and have an excellent roundness accuracy of under 0.0004 mm (0.000,016"), which can be optionally improved to under 0.0002 mm (0.000,008") during live spindle operations. The fine adjustment allows for taper corrections in the 1 µm range

during live spindle operations. Like the tailstock, the workhead is also equipped with a pneumatic lifting device to facilitate movement during setup and resetting.

The optional C-axis enables thread and form grinding, increasing the machine's potential applications. A controlled power chucking cylinder which actuates power chuck and spring collets is available for automatic workpiece clamping.

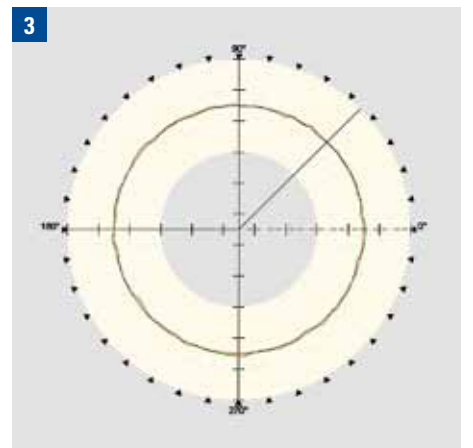

- Pneumatic lifting
- Low-maintenance
- High roundness accuracy

Tailstock

The generously dimensioned barrel, designed for the use of Morse 3 (4) taper centers, glides in the tailstock housing. The center pressure can be adjusted with the delicate precision required for grinding high-precision workpieces. The tailstock can be equipped with a hydraulically actuated barrel retraction for workpiece change-over. The fine adjustment enables taper corrections in the range below 1 μm when grinding between centers. A pneumatic lifting process facilitates movement during setup and resetting.

In order to guarantee optimum thermal stability, the tailstock is flooded with cooling lubricant, as are the barrel and the diamond holder. The machine is also equipped with an optional synchronous tailstock for direct driving of workpieces between centers.



- Taper corrections
- Barrel flooding

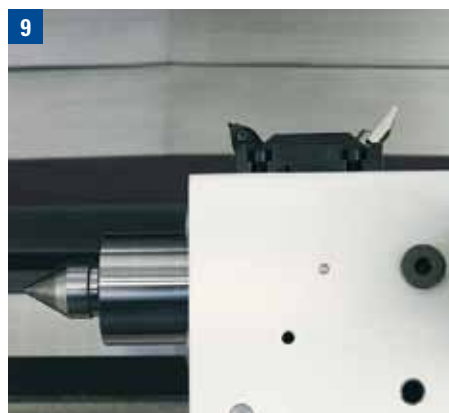

- 1 | External and internal thread grinding
- 2 | Fine adjustment for taper corrections
- 3 | Roundness during live spindle grinding operations
- 4 | Universal workhead
- 5 | Tailstock
- 6 | Fine adjustment for taper corrections
- 7 | Tailstock in «Park» position for live spindle grinding
- 8 | Dressing spindle for rotative dressing
- 9 | Dressing tool holder

Machine control and operation

The Fanuc 0i-TD CNC control with integrated PC and 15" touch screen is extremely reliable and optimally matched to the drive elements.

The control cabinet is bolted to the machine bed. The electrical equipment complies with established safety standards and is EMC-tested.

All controls are clearly and ergonomically arranged. An important role is played by the manual control unit, which facilitates setup close to the grinding process.

A special function – the Sensitron electronic contact detection device – reduces downtimes to a minimum.

- StuderWIN operator interface
- Touch screen (PC control unit 15")
- Graphic operator prompting
- PCU2 manual control unit



- 1 | Machine control
- 2 | Internal view of the control cabinet
- 3 | Manual control unit
- 4 | StuderDress integrated
- 5 | Contact detection
- 6 | Wheelhead set-up

- Latest software technology
- Pictogramming
- StuderGRIND programming software

StuderWin

StuderWIN as user interface and the software modules of StuderGRIND create a stable programming environment and contribute to the efficiency of the machine. A PC is integrated into the CNC control. The possibility of fully integrating the in-process gauging and sensor technology for process monitoring as well as contact detection and automatic balancing systems in the Windows control enable standardised programming of the different systems. The software for an internal loading system is also integrated in the control. The drive elements are optimally adapted to the control.

The sophisticated mechanical engineering concept of the S33 is completed by a grinding software program developed in-house by Studer and continuously further optimized in collaboration with customers.

This software offers:

- Pictogramming: The operator strings the individual grinding cycles together – the control unit generates the ISO code.
- Quick-Set: The software for grinding wheel alignment reduces changeover times by up to 90 %.

- Microfunctions: Free programming of grinding and dressing process sequences for optimization of the grinding process.
- The proven StuderGRIND software modules now also run under StuderWIN. A valuable asset for all customers is **StuderTechnology integrated** with the technology computer for automatic calculation of grinding parameters.

Further modules:

- StuderDress integrated**
- StuderContour integrated**
- StuderForm integrated**
- StuderThread integrated**

StuderGRIND also continues to show its strengths in offline programming. The program is created on the PC and transferred directly to the machine control unit.

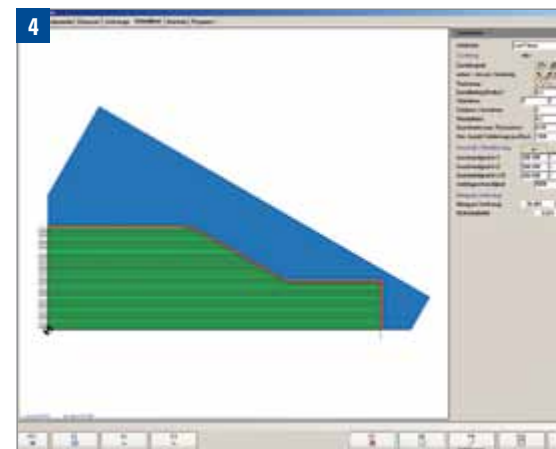



1



2

Summary key data

Range of workpieces	Shaft parts	
Dimensions	Workpiece weight approx.	5 kg (11.0 lbs)
	Workpiece length	20–300 mm (0.8" – 11.8")
	Workpiece dia.	6–100 mm (0.2" – 3.9")
	Gripper dia.	6–60 mm (0.2" – 2.4")
Workpiece feed	Prepositioned on prism conveyor	
Autonomy	max. 36 parts (with gripper dia. 30 mm (1.2")	
	and max. workpiece dia. 38 mm (1.5")	
Positioning accuracy	vertical ± 0.1 mm / horizontal ± 0.1 mm (0.004")	

STUDER smartLoad

The STUDER smartLoad is the ideal solution for automation of the S33 universal cylindrical grinding machine. The add-on loader is suitable for shaft components up to a part length of 300 mm and a diameter of up to 100 mm, thus covering a good portion of the component range possible on this machine. The dual gripper unit as a H-configuration allows a very short workpiece loading/unloading time. The workpieces are fed by a synchronized conveyor with an autonomy of maximum 36 parts. The smartLoad housing, coordinated with the machine design, enables safe and clean operation of the system.

Content of supply

- User interface integrated into machine control (Teach-In)
- SPC- and scrap channels / SPC via softkeys
- Mechanical and electrical interface

Accessories and services

There is an extensive range of accessory equipment available for all Studer cylindrical grinding machines, including centers, dressing tools, grinding wheels, clamping devices, internal grinding spindles, in-process gauging devices, etc.

The Studer Training Department organizes courses for hundreds of customers every year specializing in programming and machine use – a sound basis for optimum use of your Studer machines. Maintenance courses are tailored to the respective requirements of the maintenance departments.

On request, they can also take place on the customer's premises. Studer specialists collaborate in grinding problems, in order to achieve the optimal solution

The after sales service is able to speak the user's language and operates on a worldwide basis. This ensures that the service technicians do not have to travel far to make customer visits. The well thought-out service offer enables them to support the user to operate the machine in an optimal manner. And spare parts availability is guaranteed for a minimum of 10 years after installation.

- Commissioning
- Training
- Production support
- Warranty extension
- Maintenance
- HelpLine
- Repair
- Spare parts
- Teleservice
- Inspection
- Overhaul

- 1 | Add-on loader smartLoad
- 2 | Parts feed
- 3 | Deployment of engineers on the customer's premises
- 4 | Training on simulators



Main dimensions

Distance between centres	650/1000 mm (25.6" /39.4")
Centre height	175 mm (6.9")
Max. workpiece weight between centres	80/120 kg (176/264 lbs)

Cross slide: X axis

Max. travel	285 mm (11.2")
Speed	0,001–10 000 mm/min (0.000,04–394 ipm)
Resolution	0,0001 mm (0.000,004")

Longitudinal slide: Z axis

Max. travel	800/1150 mm (31.5"/45.3")
Speed	0,001–20 000 mm/min (0.000,04–787 ipm)
Resolution	0,0001 mm (0.000,004")
Machine table swivelling range	8.5 deg

Wheelhead

	Type: external	Type: universal
Positive stop	0 deg/30 deg	
Swivel range		–15 deg to +225 deg
Manual swivelling axis		2,5 deg Hirth
Automatic swivelling axis		1 deg Hirth
Fitting taper	dia. 63 mm (2.48")	dia. 63 mm (2.48")
Drive power	7.5 kW (10 hp) [9 kW (12 hp)]	11 kW (15 hp)
Grinding wheel right, dia. x width x bore	500 x 63 (80F5) x 203 mm 20" x 2.5" (3.15"F5) x 8"	500 x 63 (80/110F5) x 203 mm 20" x 2.5" (3.15"/4.33"F5) x 8"
Circumferential speed	up to 50 m/s (9840 sfpm)	up to 50 m/s (9840 sfpm)
Internal grinding device for high frequency internal grinding spindles		dia. 120 mm (4.73")
Speeds		24 000 – 120 000 rpm

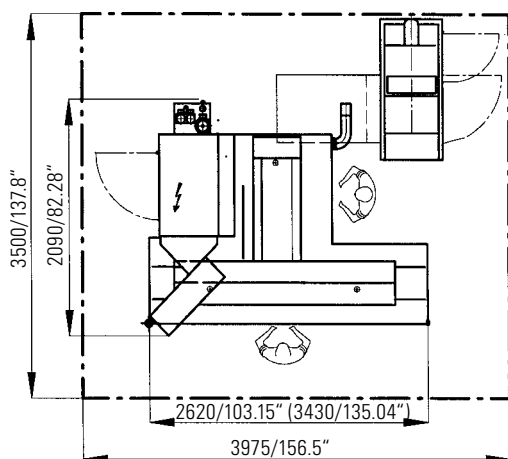

Universal workhead

Speed range	1 – 1500 rpm	1 – 1500 rpm	1 – 1500 rpm
Fitting taper	Morse 4	Morse 4	ISO 50
Spindle feedthrough	dia. 26 mm (1.02")	dia. 30 mm (1.18")	dia. 50 mm (1.97")
Drive power	3 kW (4 hp)	1,6/3 kW (2.2/ hp)	3/4 kW (4/5.4 hp)
Load during live grinding	70 Nm (52 ft lbs)	70 Nm (52 ft lbs)	70 Nm (52 ft lbs)
Roundness accuracy during live grinding	0.0004 mm (0.000,016") (Option: 0,0002 mm/0.000,008")	0.0004 mm (0.000,016") (Option: 0,0002 mm/0.000,008")	0.0004 mm (0.000,016") (Option: 0,0002 mm/0.000,008")
Option:			
C axis standard, indirect measuring system	0.0001 deg	0.0001 deg	0.0001 deg

Universal workhead

Speed range	1 – 1000 rpm	1 – 1000 rpm
Fitting taper	Morse 4	ISO 50
Spindle feedthrough	dia. 26 mm (1.02")	dia. 50 mm (1.97")
Drive power	3 kW (2.96 hp)	3/4 kW (2.96/3.95 hp)
Load during live grinding	100 Nm (74 ft lbs)	250 Nm (186 ft lbs)
Roundness accuracy during live grinding	0.0004 mm (0.000,016") (Option: 0.0002 mm/0.000,008")	0.0004 mm (0.000,016") (Option: 0.0002 mm/0.000,008")
Option:		
C axis standard, indirect measuring system	0.0001 deg	0.0001 deg

Tailstock

Fitting taper	MK3/MK4
Travel of barrel	35/50 mm (1.38"/1.97")
Diameter of barrel	50 mm (1.97")
Fine adjustment for cylindricality corrections	±40 µm (0.0016")

Control unit

Fanuc 0i-TD Standalone Panel /

Guaranteed working precision

Straightness of the surface line	
Gauge length 650 mm (25.6")	0.0025 mm (0.000,10")
Gauge length 1000 mm (39.4")	0.0030 mm (0.000,12")

Connected loads

Total connected load	20 kVA
Air pressure	5.5 bar (80 psi)

Total weight

Distance between centres 650 mm (25.6")	4000 kg (8 800 lbs)
Distance between centres 1000 mm (39.4")	5000 kg (11 000 lbs)

The information given is based on the technical levels of our machine at the time of this brochure going to print. We reserve the right to further develop our machines technically and make design modifications. This means that the dimensions, weights, colours, etc. of the machines supplied can differ. The diverse application possibilities of our machines depend on the technical equipment specifically requested by our customers. The equipment specifically agreed with the customer is therefore exclusively definitive for the equipping of the machines, and not any general data, information or illustrations.



KÖRBER
SCHLEIFRING

Fritz Studer AG
CH-3602 Thun
Telephone +41-33-439 1111 · Telefax +41-33-439 1112
www.studer.com

ISO 9001
VDA6.4
certified

